

TCS When installing TCS:BUS systems the general safety regulations for telecommunication systems according to VDE 0800 must be observed. Inter alia:
> separated cable routing of high and low voltage lines,
> minimum distance of 10 cm in case of a common cable routing,
> use of separators between high and low voltage lines within shared cable ducts,
> use of standard telecommunication lines, e.g. J-Y [St] Y with 0.8 mm diameter,
> already existing lines (modernisation) with deviating cross-sections can be used in compliance with the loop resistance.
> Observe the generally accepted standards for structured wiring of communication systems according to EN50173-1 when installing TCS:VoIP devices. Always use data cables with the standard CAT5e at least.

CAUTION! Ensure, that the VoIP communication of TCS devices is not encoded. Protect your network and WLAN from unauthorised access.
> Change the password after the commissioning.
> Be careful when linkin-up the device to the internet. Ask your network administrator.

Requirements to protect against lightning
CAUTION! Device damage due to overvoltage. By suitable lightning protection measures it has to be ensured that the electric voltage of 32 V DC at each connection is not to be exceeded.

PRODUCT DESCRIPTION
IWV5411-0145 and ISW5410-0145 are P audio indoor station for full duplex VoIP hands-free talking. The device is exclusively suitable for indoor usage. Type of mounting: surface-mountas table-top device with desktop accessory ZIT5000-0030.

For applications, which differ from the intended use or goes beyond it, the manufacturer accepts no liability.

INDICATION AND OPERATING ELEMENTS

- Latch**
- Loudspeaker**
- Microphon**
- Function button 1**
> SIP-call 1
> Ring tone selection for SIP address group 1
> URL, DTMF and HTTP(s)
- Function button 2**
> SIP call 2
> Action URL
> DTMF (when a voice connection is established)
> Send HTTP(s) - request
> Press longer than 3 sec: ambient illumination on / off
> Ring tone selection for floor call

PRODUCT INFORMATION (brief)
IP-audio- and IP-video-indoor Station
Series TASTA

ISW5410-0145 Audio
IWV5411-0145 Video

German / English



SCOPE OF DELIVERY

- 1 x indoor station
- 1 x mounting tray
- 1 x product information (brief)
- 1 x user manual

NOTES ON THE INSTRUCTION

The installation guide refers exclusively to qualified electricians. Please scan the QR Code for detailed information or go to: [tcsag.de/download](https://www.tcsag.de/download).

The installation guide contains important notes on the intended use, installation and commissioning of the product. Please keep the installation guide in a suitable place where it can be easily accessed for maintenance and repair works

SAFETY INSTRUCTION

General safety instruction

Assembly, installation, commissioning and repair of electronic devices must be carried out by qualified electricians. Observe the latest regulations and standards for system installations.

WARNING! Danger due to electric shock.
Observe the safety regulations according to DIN VDE 0100, when working on main power connections of 230 V.

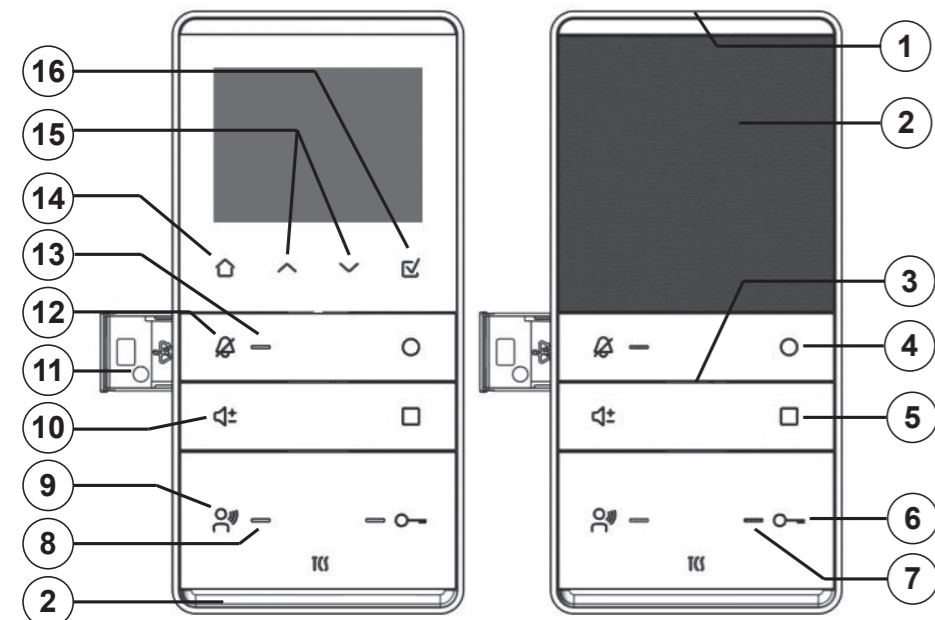

- Door release button**
> Open the door (action: URL, DTMF)
> Quit speaking: call is terminated after 4 sec
> Quit speaking: after sending a DTMF
> Ring tone selection for unknown SIP calls
- Door release indication**
> OFF: door opener is ready for operation
> ON for 3 sec door is opened
- Indication for calling/speaking (LED green)**
> OFF: ready for operation
> ON: call, speaking is active
> Blinks: busy speech channel
- Speech button**
> Shortly press: call acceptance, activate speaking
> Quit speaking
> In stand-by mode: call from SIP contacts
> Ring tone selection: SIP address group 2
- Volume button**
> Setting the ring tone volume in 4 steps (when NO voice connection is established)
> Setting the volume voice output in 4 steps (when a voice connection IS established)
- Smart Slot**
> For additional signalling of a door call, can be ordered as accessory
- Call-OFF button**
> Shortly press: activate ring tone mute
> Press for 8 sec: initiate / quit the ring tone selection
- Call display OFF (LED red)**
> OFF: call OFF is deactivated
> ON: call OFF is activated
- Homebutton (OSD-Menu)**
> Shortly press: image activation
> Press again: the main menu is called up (press the button twice to directly call up the main menu)
- Navigation button (OSD-Menu UP and Down)**
> Navigation buttons (arrows): navigate in the menu and adapt menu points
> Confirmation button (checkmark): confirm a selection, change-over between different cameras
- Confirm button**
> Confirm selction in OSD-Menu

MOUNTING AND INSTALLING

Mounting height
For an optimal operation, install the video indoor station 1.60 m (upper egde of the device) above the ground.

Install the mounting tray
Observe the installation position of the mounting tray. It is marked with an arrow and the designation TOP.

The mounting tray can be installed directly to the wall or on a flush-mount socket.

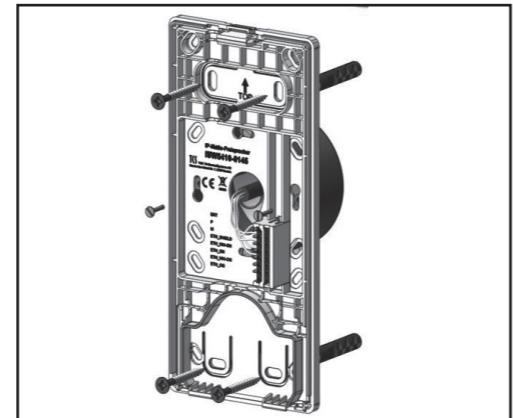

Guide the connection cable through the cable gland. Connect the wires to the terminal according to the labeling

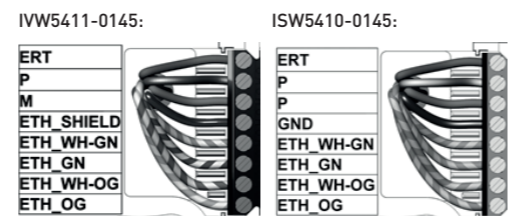

CAUTION! Device damage due to interchanging the connections between ISW5410 and IWV5411. Do not interchange the connections of the ISW5410 with those of the IWV5411. The device may be damaged as a result.

Fix the mounting tray with suitable screws to the wall or on the flush-mount socket.

Snap-on the device on the mounting tray
Put the device onto both adjustment increments [1]. Press the device against the latch until it snaps on [2].

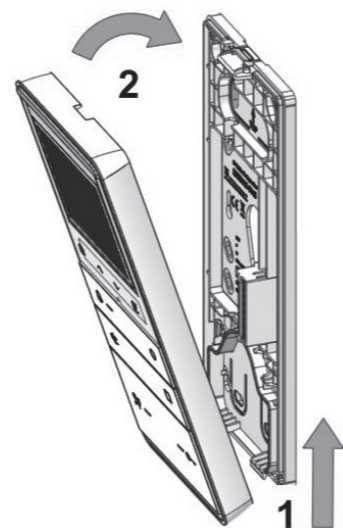

Remove the device from the mounting tray
Insert a screw driver with slight pressure into the release opening [1]. Pull off the device to the front at its upper side. Lift the device out of the adjustment increments [2].

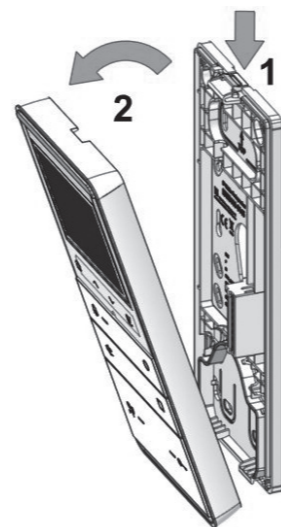

EXAMPLE CIRCUIT

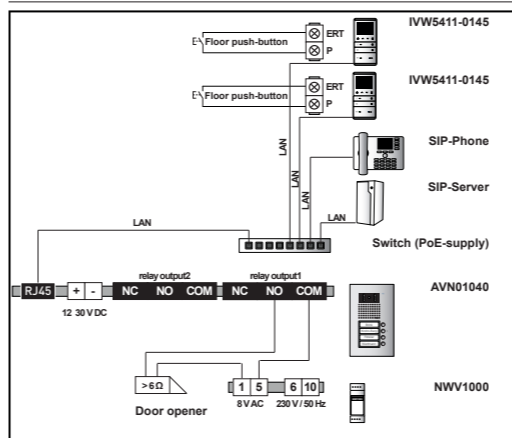

COMMISSIONING

- System requirements**
- operating system Windows 7, 8, 8.1 or 10
 - required hard disk space: 10 MB
 - graphic card with at least 1280x1024 pixel
 - Net Framework 4.0

Preparations

- switch [PoE] or router
- Android-Phone from Android-Version 9
- Download snipdoo® INSIDE from Google Play Store. You can scan the QR-Code for downloading.



- The snipdoo® INSIDE app is required for configuration.
- Connect your snipdoo® INSIDE with the network (WiFi), where your indoor station is connected.
- The App discovers automatically your devices for configuration.

Establish a network connection

- Install the devices of the system completely.
- Check the wires against each other on short-circuit.
- Ensure, that an external voltage source is available or the supply via PoE is ensured.
- Connect the IP indoor station via network cable to your network (PoE switch, router).
- Connect the Windows PC to your network.
- Switch on the voltage supply.

The IP indoor station obtains the network address automatically, if a DHCP server exists. If this is not the case, you can set the network address manually via the configuration software.

After a voltage breakdown the IP indoor station restarts automatically. Switching off the power supply during a saving procedure or software update can cause a loss of data or a technical defect of the device. We are continually improving our products. We recommend that you visit our homepage regularly in order to find software updates for your device.

Ausführliche Informationen zu den Servicebedingungen für TCS IP-Anlagen finden Sie unter: <https://www.tcsag.de/rechtliches/funktionsbedingungen-fuer-tcs-produkte-mit-ip/>

Error detection and indication

If the IP indoor station recognises an error, the error is indicated when alls LEDs are flashing. Pressing any button of the device triggers the output of an error tone. The optical error indication stays active as long as the error has been corrected.

Error tone	
Error causes	button stuck (was pressed longer than 15 s)
Troubleshooting	loosen the button at the device or floor push button, device is in stand-by mode again
Error tone	
Fehlerursachen	no ethernet
Beseitigung	check the connecting cable
Error tone	
Error causes	no DHCP
Troubleshooting	check the settings
Error tone	
Error causes	no SIP server
Troubleshooting	check the connecting cable and the settings

Load factory settings

For further information on loading the factory settings refer to the more detailed product information. Therefore scan the following QR code or enter the download area on our website.

TECHNISCHE DATEN

	ISW5410-0145	IWV5411-0145
Supply voltage	18 - 26 V DC (DC power supply) IEEE802.3af Mode A (PoE)	
Ambient temperature	- 5 ... + 40 °C	
Housing	plastic ASA	
Dimensions (in mm)	H 194 x B 94 x T 21 (with Mounting try)	
Degree of protection	IP30	
Weight	190 g	227 g
LAN interface	IEEE802.3u 10/100BASE-TX/s, Auto MDIX, Screw terminal	
Supported protocols	IPv4, TCP, UDP, DHCP, HTTP, SIP 2.0 (UDP), RTP, Syslog, ICMP, ARP	
Audio codecs	G.711a/μ, G.722 G.711a/μ, G.722	
Audio transmission	Voll-Duplex, Echo-Cancelation, Automatic Gain Control	
Video module		TFT-Color
Screen size	8,9 cm (3,5 Zoll)	
Screen resolution	320 x 240 Pixel, QVGA	
Video codecs	MJPEG	

For further information on configuration and operation refer to the more detailed product information. Therefore scan the following QR code or enter the download area on our website.

NOTES

CONFORMITY
Declarations of conformity are available for download at www.tcsag.de. Downloads, trade information.

INFORMATION ON DISPOSAL
Dispose the device separately from domestic waste via a collection point for electronic scrap. Ask your county administration for the responsible collection point.

Dispose the parts of the packaging in collecting tanks for cardboard and paper resp. plastics.

WARRANTY

We offer a simplified processing in case of warranty for qualified electricians.
> Please contact the TCS HOTLINE under 4194 9881-188 or hotline@tcsag.de.
> Our standard terms and conditions of sale you'll find under www.tcsag.de, Downloads as well as our current product catalogue.

SERVICE

Please send your questions and inquiries to TCS HOTLINE 04194 9881-188 or hotline@tcsag.de

TCS TürControlSysteme AG
Geschwister-Scholl-Strasse 7
D-39307 Genthin
Telefon: +49 3933 8799-10
Fax: +49 3933 8799-11
www.tcsag.de

TCS Österreich GmbH
Gewerbepark 21
A-2821 Lanzenkirchen
Telefon: +43 2627 45266-0
Fax: +43 2627 45266-20
www.tcs-austria.at