

Bedienungsansicht

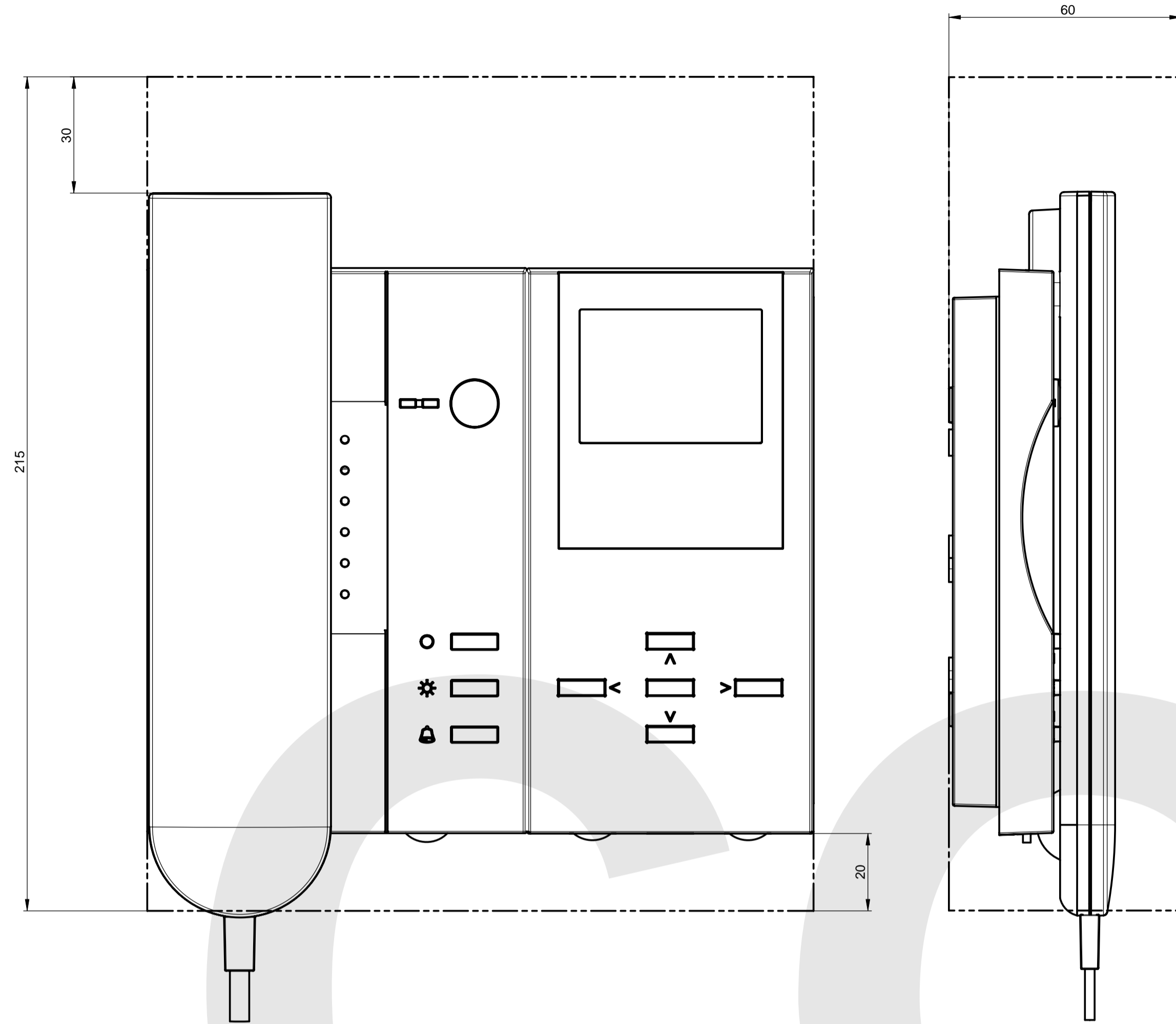

Montageansicht

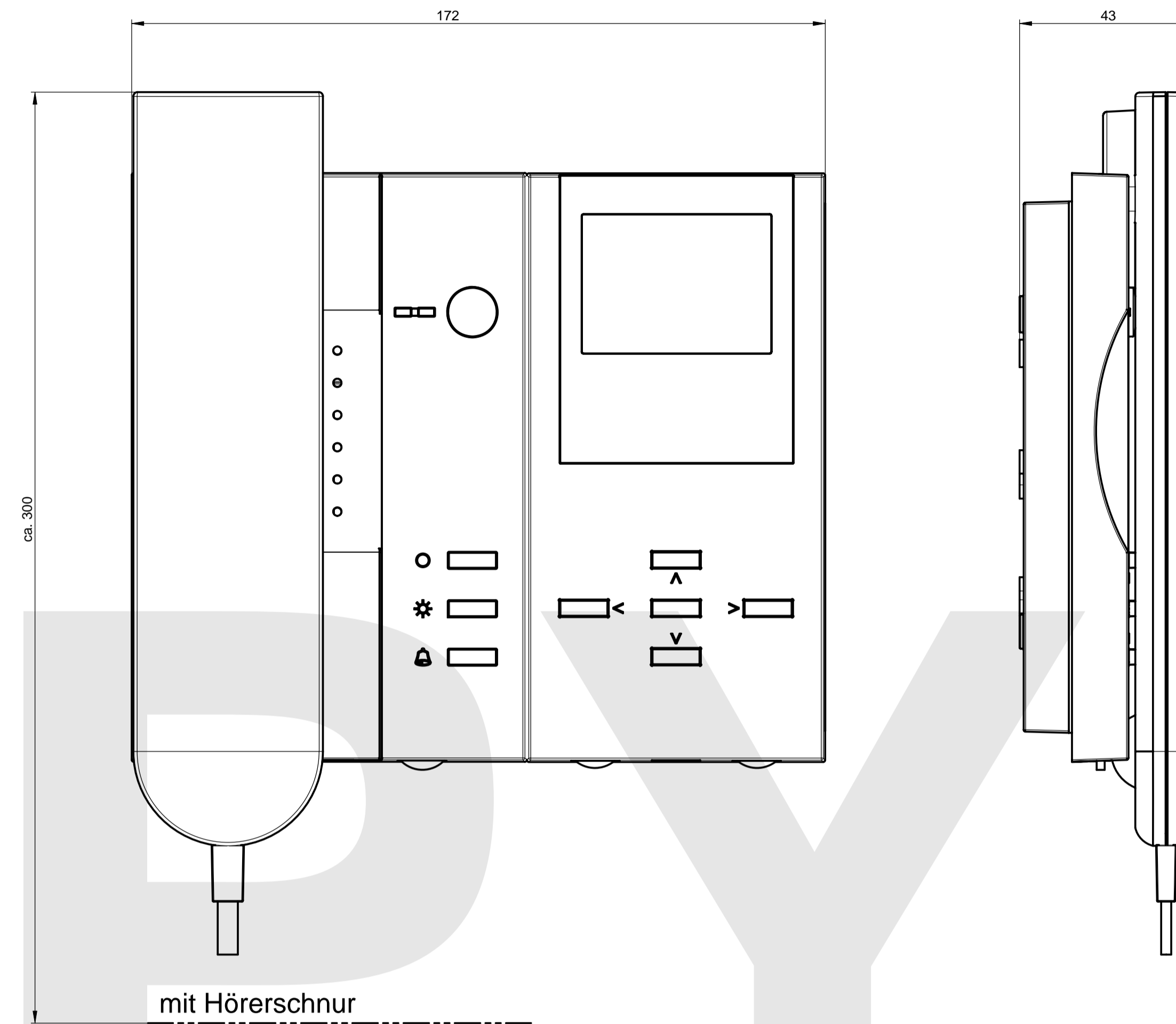

Gehäusemaß

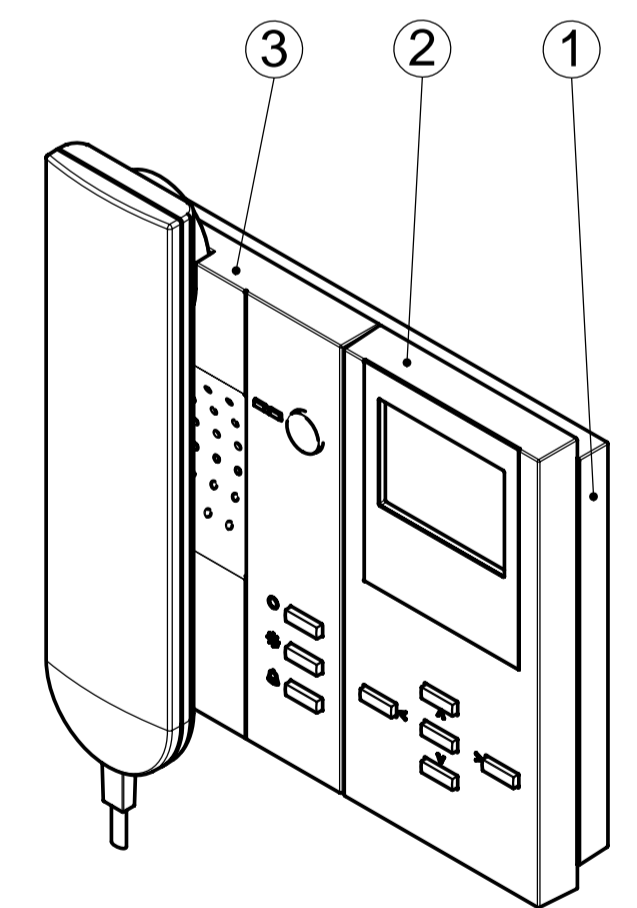
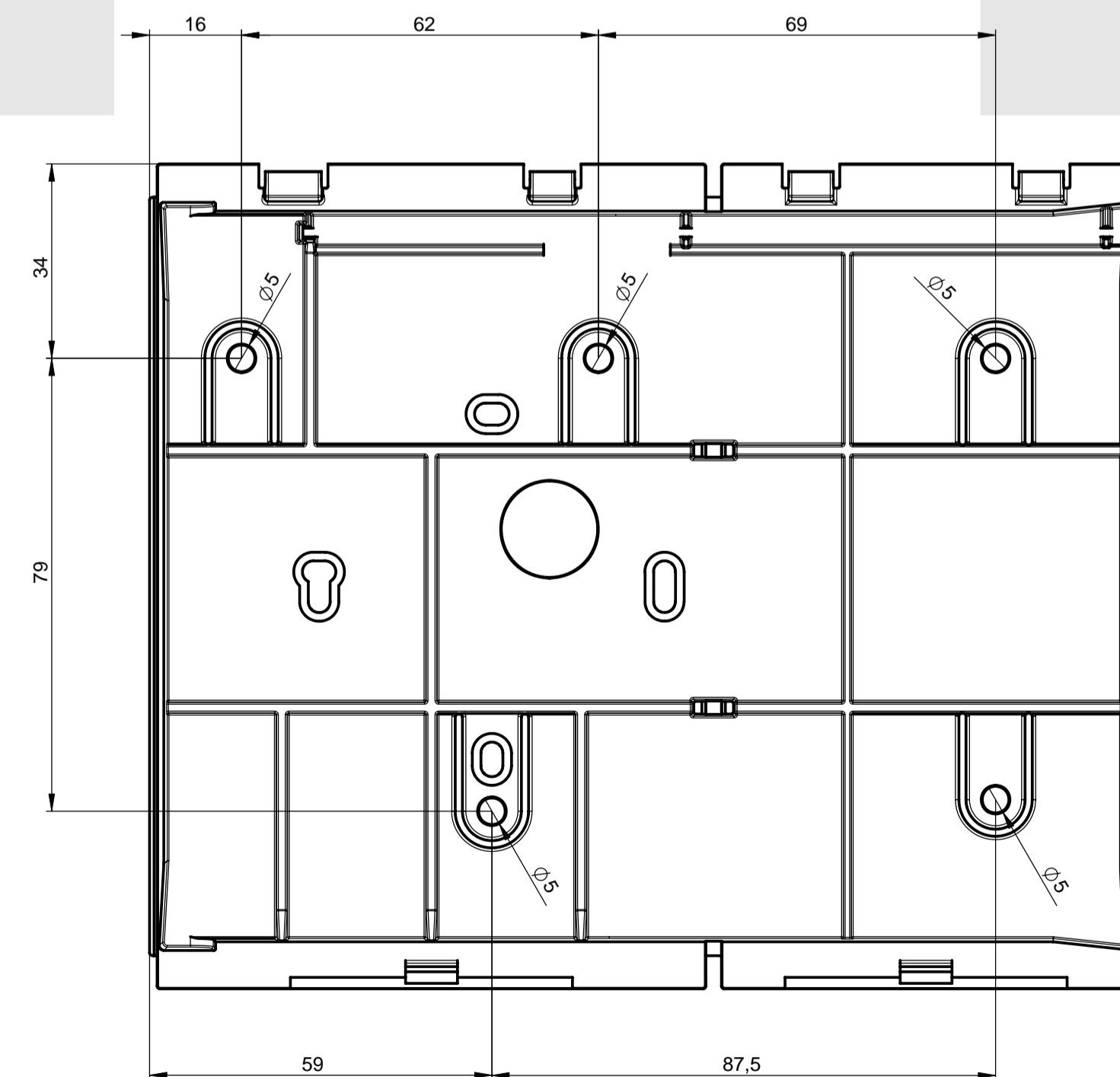
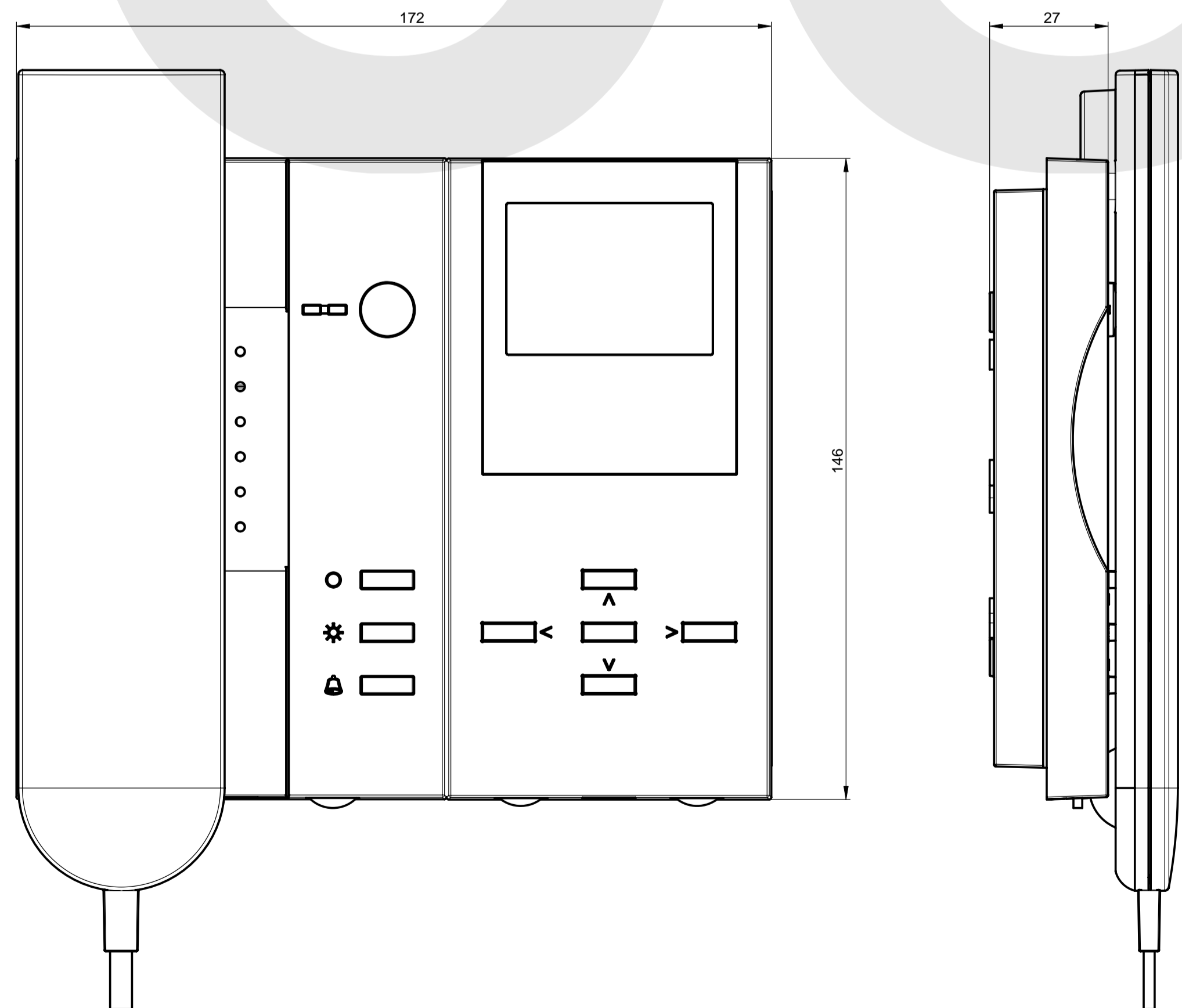

M1:2

3	1	D-LINE mit Hörer	038-630-00-00	-	-	-	-	-
2	1	IMM Video Modul komplett	038-204-00-00	-	-	-	-	-
1	1	Unterschale Erweiterung 1	038-103-E3-01	ABS	-	-	-	-
POS/Stck		BEZEICHNUNG	NORM/ZCHG.-NR./BESTELL-NR.	MATERIAL	ABMESSUNG	BEMERKUNG	Fert	
allg. Toleranzen nach:			Freigabe:	Maßstab: 1:1(1-2)	Gewicht: -gr.			
			Datum	Name	IMM1300-0140		Blatt	
			Bearb.	Fehling	Vertriebszeichnung		1	
			Gepr.				1 Bl.	
			TCS		038-500-04-01-00		EDV Nr.: 038-500-04-01-00 IMM1300-0140 Vertriebszeichnung DIN A1	
Zust.	Aenderung	Datum	Name					