

Bedienansicht

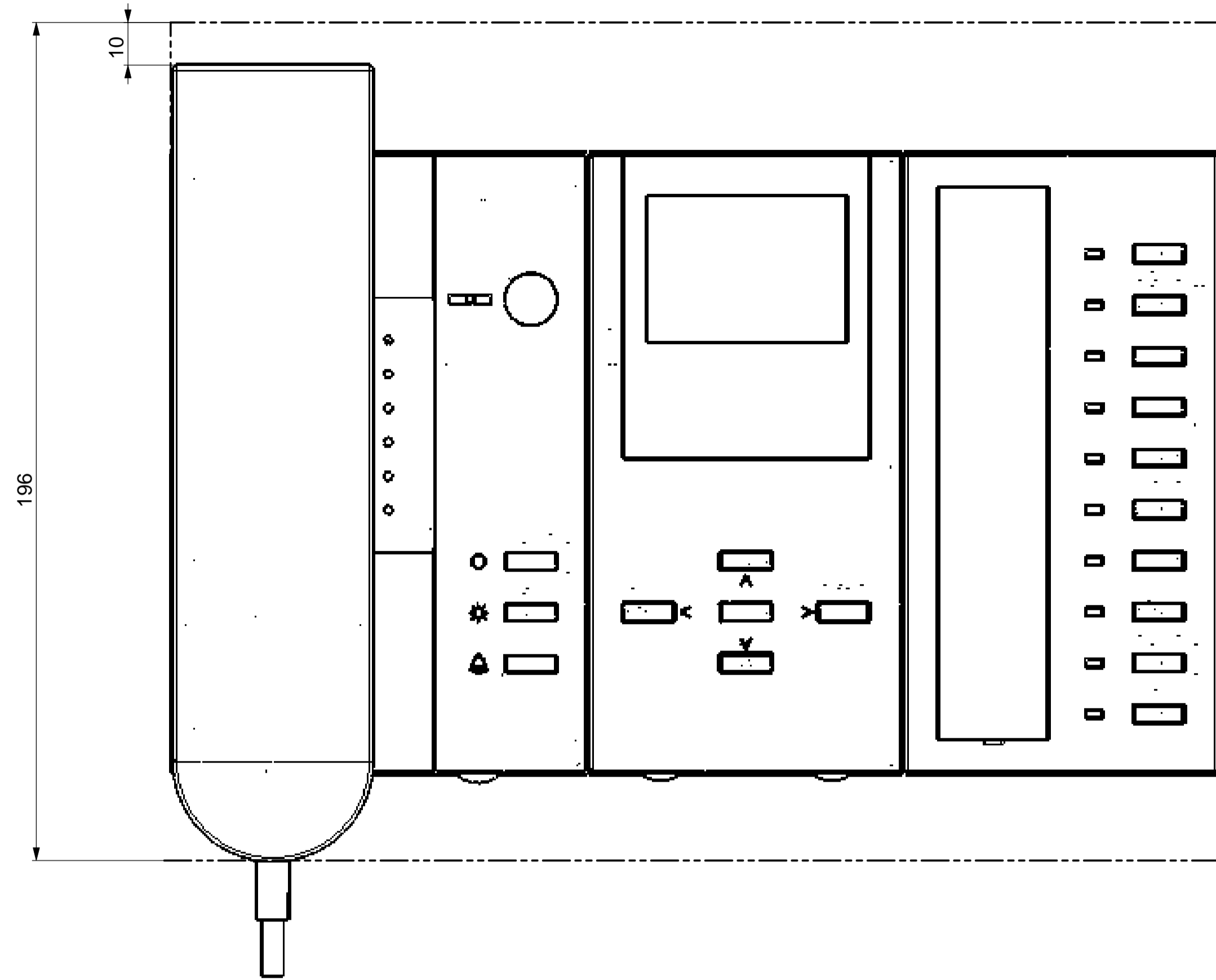

Montageansicht

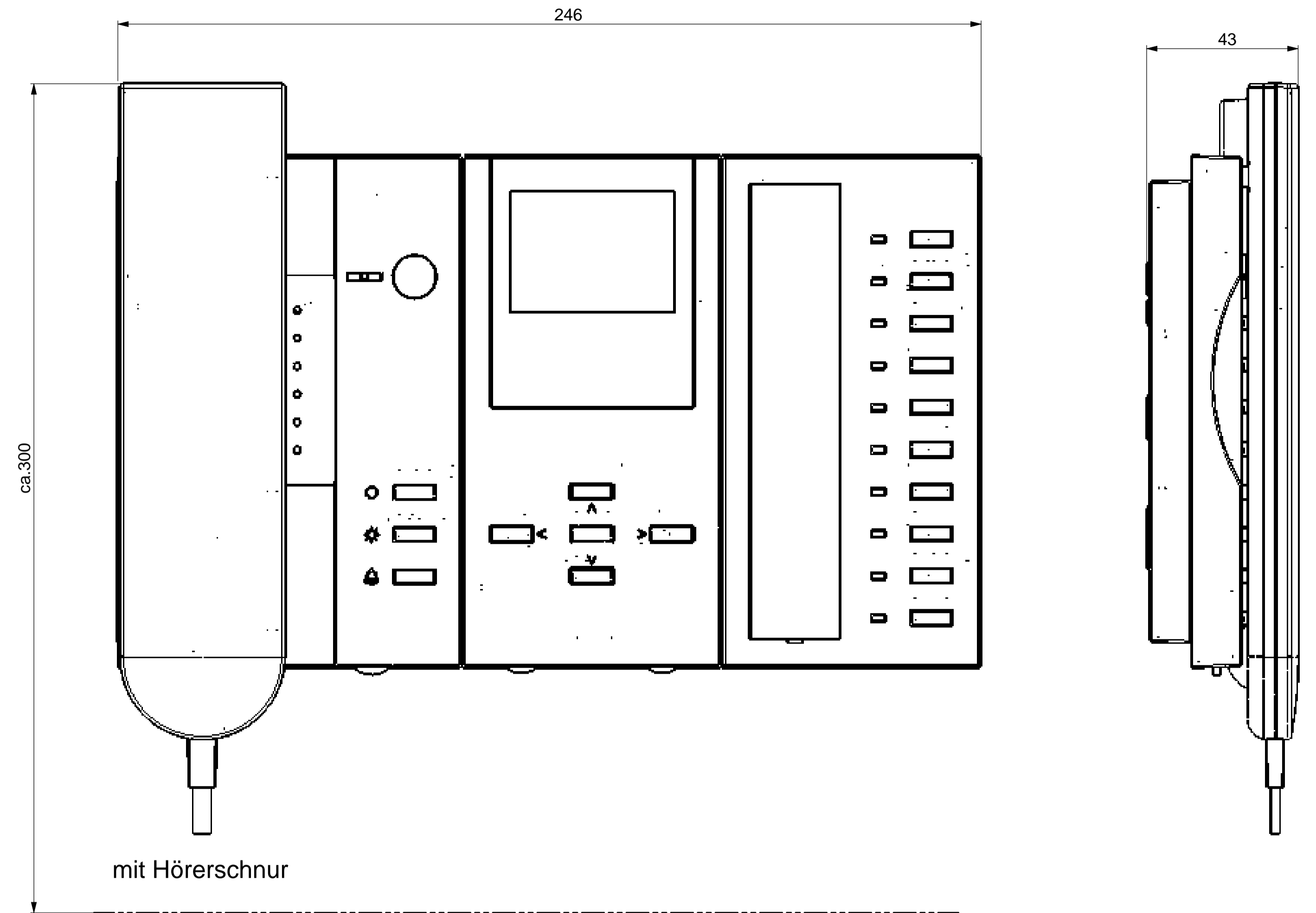

Gehäusemaß

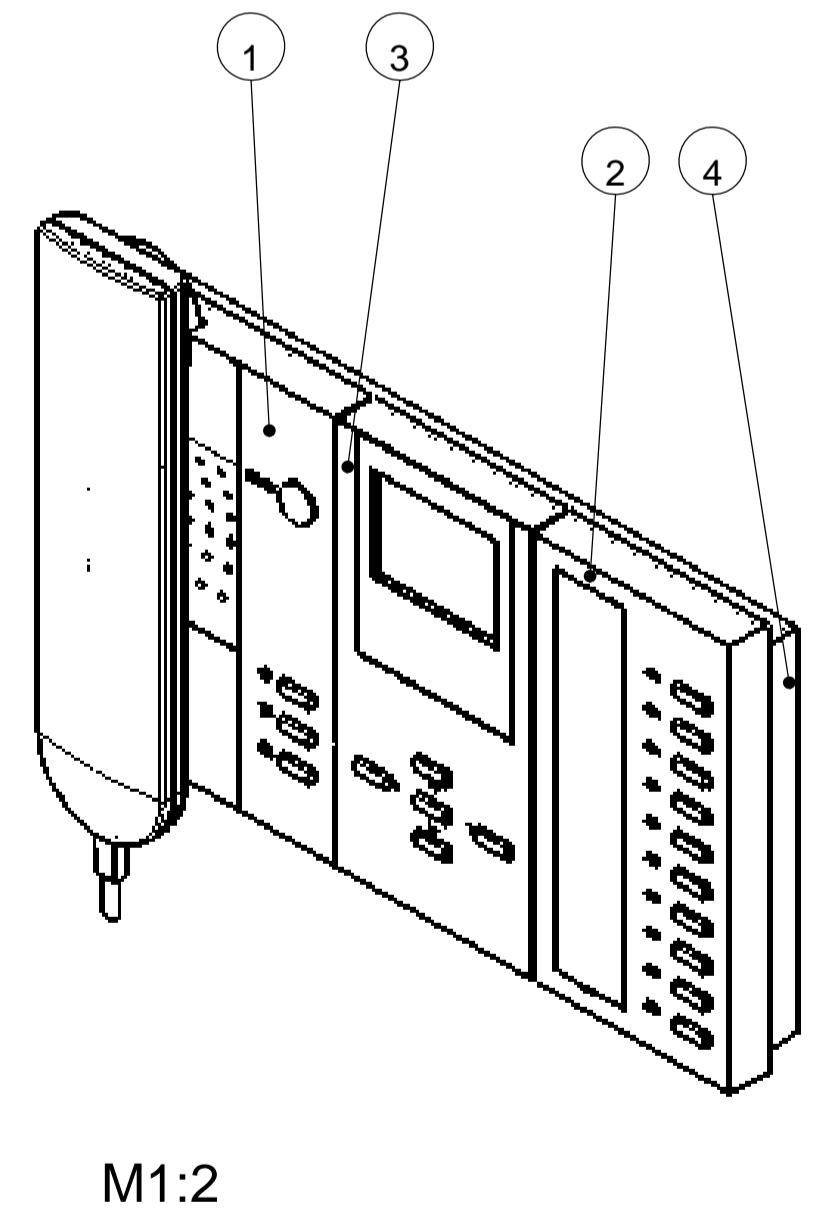
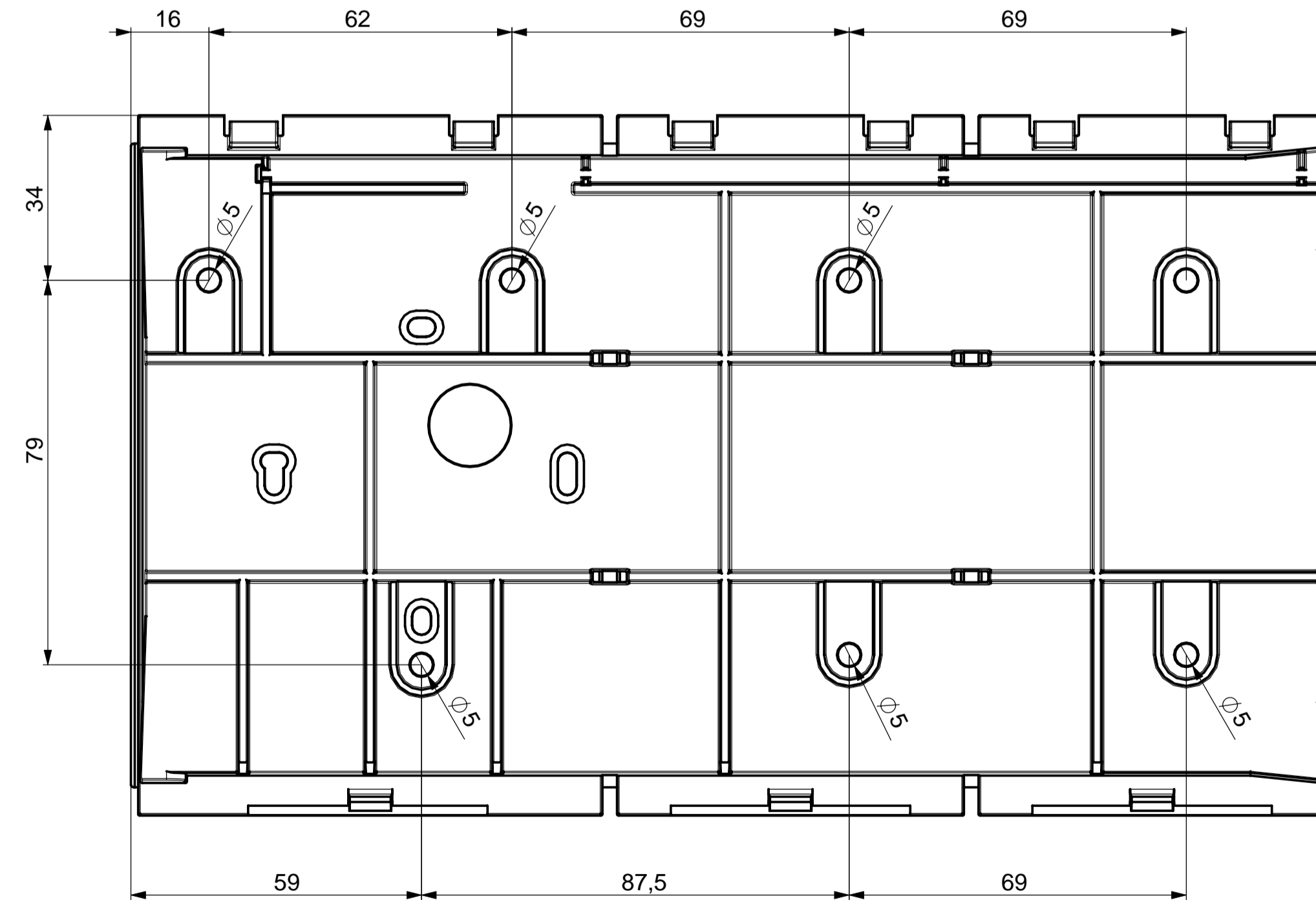
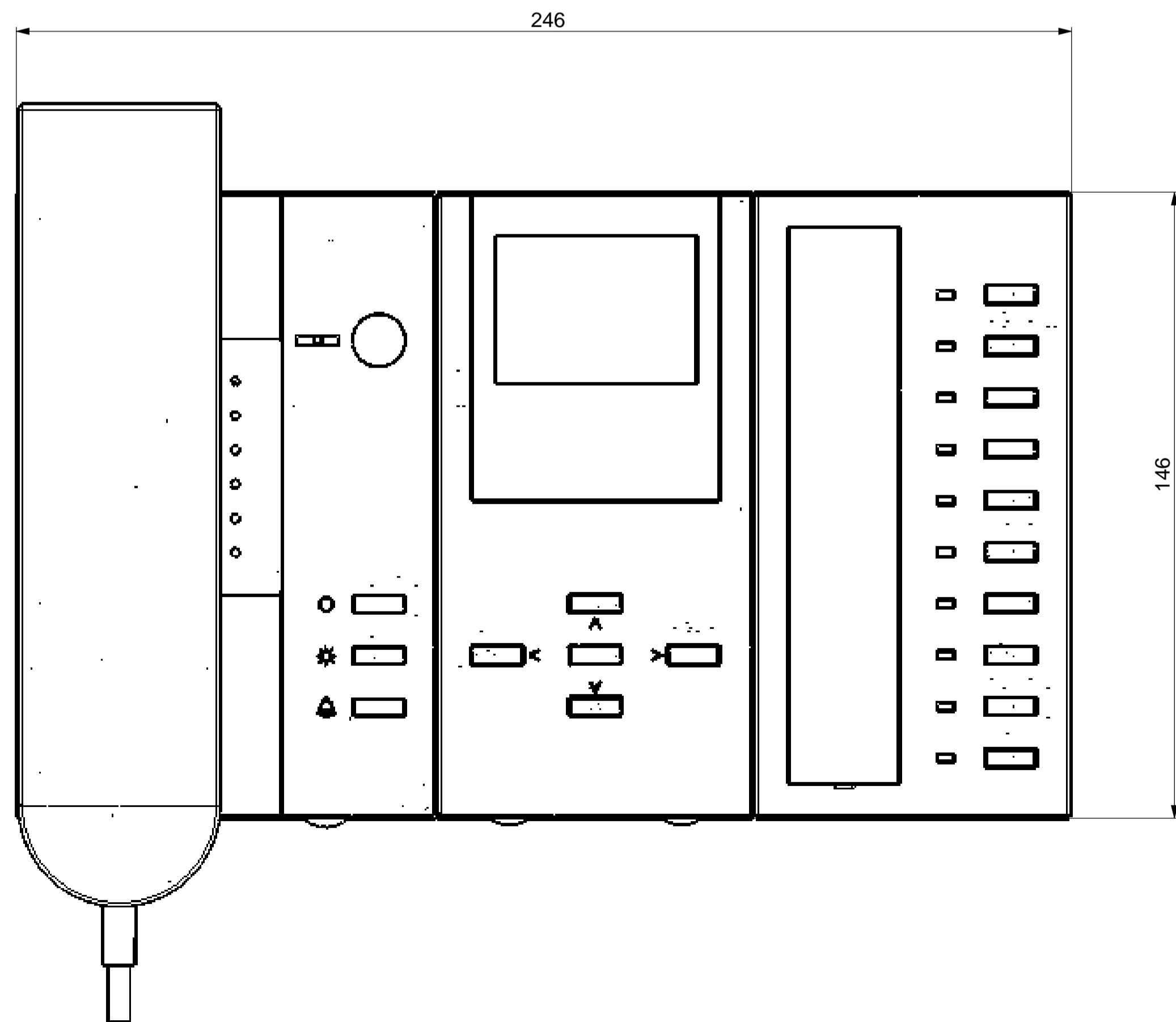

POS/	Stück	BEZEICHNUNG	NORM/ZUG- NR/BESTELL-NR.	MATERIAL	ABMESSUNG	BEMERKUNG	Fert.
4	1	IMM Unterschale Erweiterung2	038-203-05-01	ABS	-	-	-
3	1	IMM Video Modul komplett	038-204-00-00-00	-	-	-	-
2	1	Oberschale	038-104-E3-01	ABS	-	-	-
1	1	Oberschale	038-001-00-01-04	ABS	-	-	-

allg. Toleranzen nach:		Freigabe:	Masstab: 1:1 (2)	Gewicht: gr.
			Halbzeug: (if present, other Zuehung)	Werkstoff:
Datum	Name	IMM1310-0140		
25.05.2007	Fahling	Vertriebszeichnung		
Gepr.		038-500-05-01-00		
		EDV Nr.: 038-500-05-01-00 IMM1310-0140 Vertriebszeichnung		
Zust.	Aenderung	Datum	Name	Blatt 1 / 1 Bl. DIN A1